

TOWER BOLT & HINGES

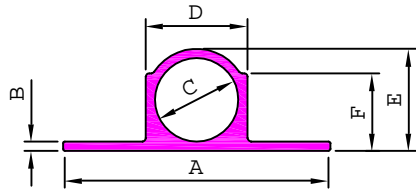

Sl No	Section No	A	B	C	D	E	F	Weight kg/m
1	18001	24.50	0.75	8.63	10.10	10.10	8.15	0.121
2	18002	31.75	1.39	9.90	12.45	12.45	9.52	0.248
3	18003	32.00	1.60	11.00	14.00	14.00	11.00	0.302
4	18004	31.75	1.32	10.05	12.70	12.80	11.43	0.265
5	18005	31.75	1.52	10.28	12.82	12.82	9.52	0.253
6	18006	38.00	2.50	13.00	18.00	18.00	14.00	0.570
7	18007	44.00	2.00	13.00	17.00	17.00	13.00	0.493
8	18008	30.00	0.75	9.90	11.40	11.40	9.50	0.156
9	18009	25.00	1.35	8.50	11.00	11.20	9.00	0.202
10	18010	29.00	1.25	9.50	11.80	12.00	9.00	0.213
11	18011	37.00	1.00	11.70	13.60	13.70	10.50	0.229
12	18013	37.50	1.70	12.40	15.70	15.80	12.00	0.379
13	18015	31.75	1.70	10.20	12.40	12.40	9.70	0.244
14	18016	38.00	2.30	12.60	17.10	17.10	13.00	0.506
15	18017	31.20	1.57	9.70	11.90	11.90	9.10	0.229
16	18022	30.75	1.02	9.50	11.30	11.30	9.00	0.176
17	18023	31.75	1.10	10.20	12.10	12.10	9.50	0.197
18	18024	25.00	1.20	8.50	11.20	10.60	9.00	0.186
19	18025	38.00	1.80	12.50	16.10	16.10	13.50	0.419
20	18026	30.00	1.20	9.30	11.20	11.20	8.50	0.184
21	18027	37.50	2.00	12.80	16.50	16.50	13.50	0.439
22	18029	37.00	2.20	12.00	15.00	15.50	11.70	0.396
23	18030	37.00	1.06	12.00	13.40	13.40	10.80	0.205
24	18031	25.40	1.45	8.00	10.50	10.40	8.75	0.194
25	18033	23.50	0.76	8.50	9.85	9.85	8.00	0.114
26	18034	28.00	0.83	9.50	10.75	10.75	8.50	0.131
27	18035	37.50	2.70	12.80	15.70	15.70	11.90	0.414
28	18036	36.00	1.85	12.00	14.90	14.90	11.00	0.342
29	18037	30.00	0.98	9.50	10.90	10.90	8.60	0.150
30	18038	44.00	2.00	13.40	16.40	16.50	14.50	0.450
31	18039	32.00	1.25	11.00	13.40	13.40	10.50	0.246
32	18040	37.00	1.83	12.00	15.00	15.00	11.70	0.354
33	18041	37.00	0.93	12.00	13.20	13.20	10.40	0.182
34	18042	23.50	0.70	8.50	9.80	9.80	7.95	0.109
35	18043	28.00	0.59	9.50	10.68	10.68	8.00	0.113
36	18044	31.75	1.10	9.90	12.10	12.10	9.20	0.204
37	18045	32.00	1.30	11.00	13.60	13.60	10.80	0.262
38	18047	32.00	1.10	11.00	13.20	13.20	10.30	0.228
39	18049	38.00	2.35	13.00	17.50	17.50	13.20	0.520
40	18051	31.00	1.10	9.40	11.40	11.40	8.70	0.188
41	18052	31.50	1.20	10.80	12.80	12.80	10.10	0.216
42	18053	32.00	1.50	10.80	13.00	13.00	9.80	0.242
43	18054	25.50	1.50	8.50	11.30	11.30	9.10	0.219

Sl No	Section No	A	B	C	D	E	F	Weight kg/m
44	18055	31.75	1.40	10.20	12.40	12.40	9.10	0.226
45	18056	31.20	1.35	9.70	11.70	11.70	9.00	0.206
46	18057	38.00	1.90	12.60	16.20	16.20	12.60	0.419
47	18058	38.00	2.30	13.00	17.40	17.40	13.20	0.509
48	18059	31.75	0.95	10.20	12.00	12.00	8.80	0.180
49	18060	44.00	1.65	12.80	15.80	15.80	13.80	0.406
50	18061	38.00	1.80	13.00	16.55	16.55	13.30	0.420

18014

0.217 kg/m

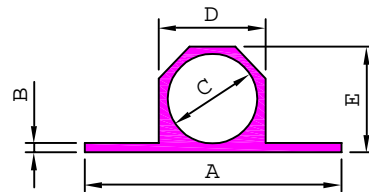
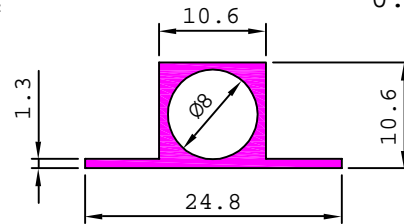

Sl No	Section No	A	B	C	D	E	Weight kg/m
1	18018	31.80	1.50	9.80	12.40	12.70	0.261
2	18019	32.00	1.35	10.80	13.10	13.50	0.255
3	18020	38.00	1.90	12.70	16.00	16.40	0.414

HINGES - FLAT LEG

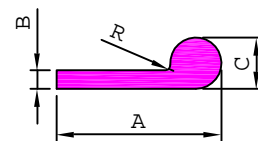

Sl No	Section No	A	B	C	R	Weight kg/m
1	18206	26.00	3.00	9.00	1.50	0.322
2	18201	31.75	3.96	7.95	1.50	0.397
3	18202	34.92	6.35	9.53	2.00	0.642
4	18205	40.00	3.25	9.00	1.50	0.456
5	18203	75.00	5.00	18.00	5.00	1.517
6	18204	105.00	3.25	9.00	2.00	1.028

18050

1.258 kg/m

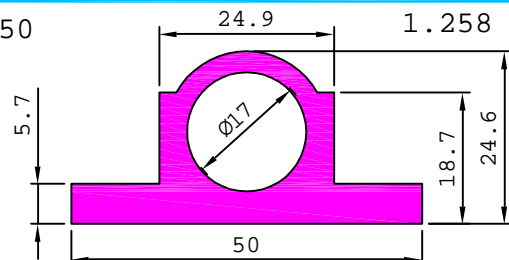

HOLLOW HINGES & SPECIAL HINGES

HINGES - TAPERED LEG

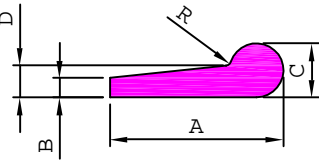

SL. No.	Section No.	A	B	C	D	R	Weight kg/m
1	18304	36.50	3.20	10.00	4.00	1.50	0.485
2	18301	36.50	3.18	9.53	3.81	-	0.460
3	18303	44.45	3.96	12.70	4.80	1.50	0.721

HINGES - HOLLOW

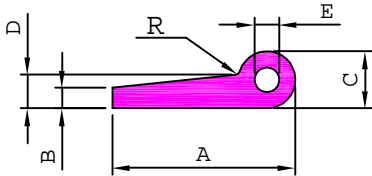

SL. No.	Section No.	A	B	C	D	E	R	Weight kg/m
1	18351	25.00	2.60	6.10	2.60	3.60	-	0.189
2	18357	25.25	3.10	6.50	3.10	3.20	1.50	0.231
3	18359	25.60	3.10	6.80	3.10	3.40	--	0.237
4	18361	24.30	2.10	6.00	2.60	3.60	--	0.170
5	18419	35.50	2.90	9.00	3.40	5.00	--	0.355
6	18353	35.76	3.10	9.52	3.60	5.00	-	0.390
7	18354	36.50	3.20	10.00	3.80	4.00	1.50	0.444
8	18356	37.00	4.00	11.00	4.00	5.55	1.50	0.489
9	18355	37.00	4.00	11.00	4.76	5.55	-	0.515
10	18360	36.51	3.15	9.52	4.15	5.00	0.50	0.418

18401

0.343 kg/m

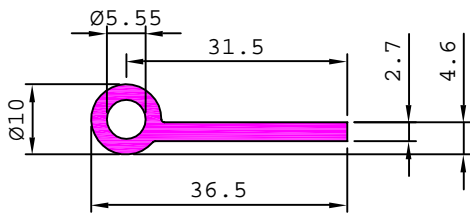

18402

0.450 kg/m

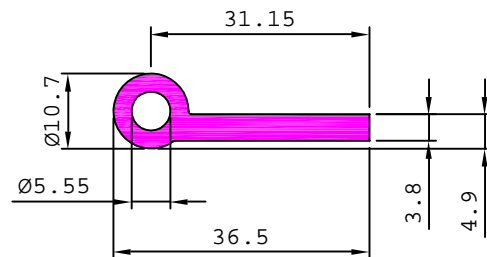

18405

1.125 kg/m

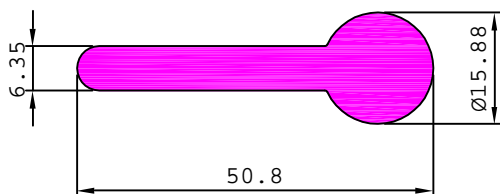

18406

1.515 kg/m

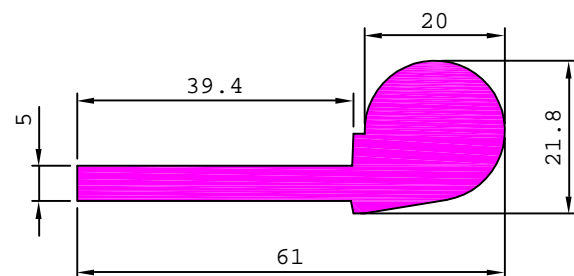

18407

1.683 kg/m

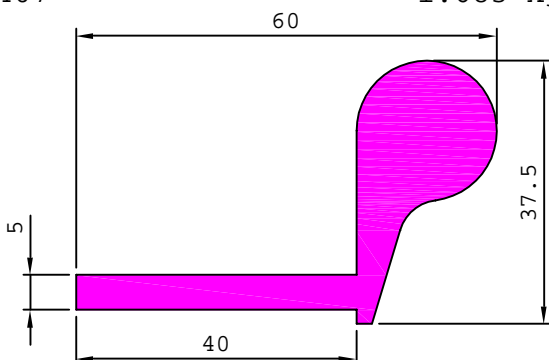

18408

1.520 kg/m

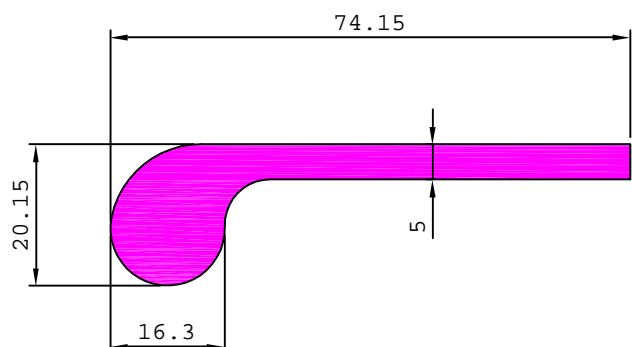

SPECIAL HINGES

18410 0.844 kg/m

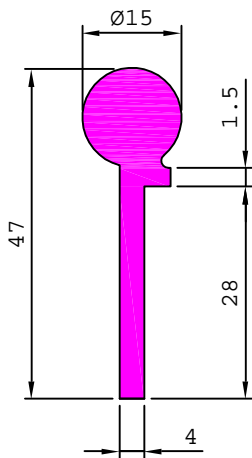

18413 1.755 kg/m

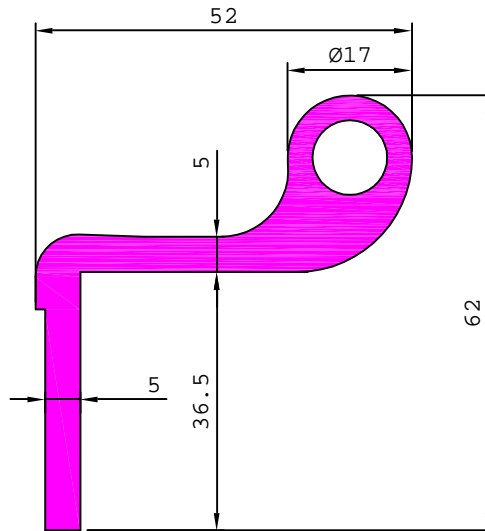

18414 1.102 kg/m

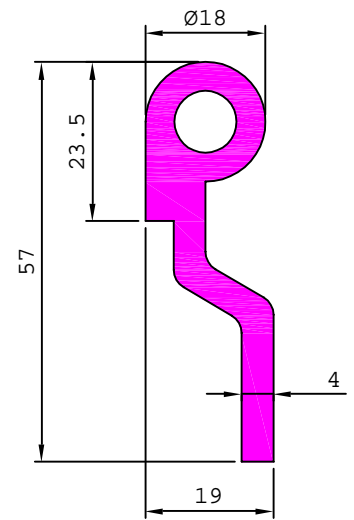

18415 0.628 kg/m

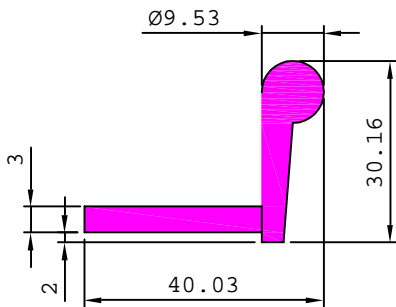

18416 0.112 kg/m

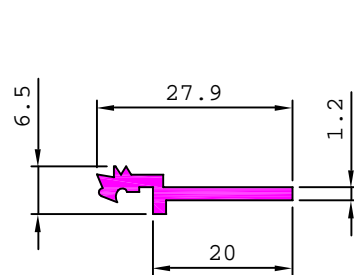

18417 0.465 kg/m

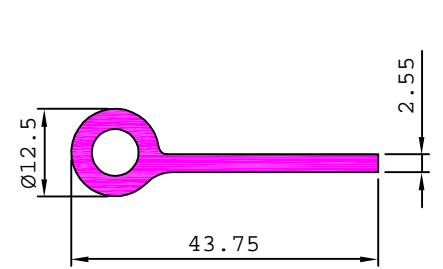

18423 1.063 kg/m

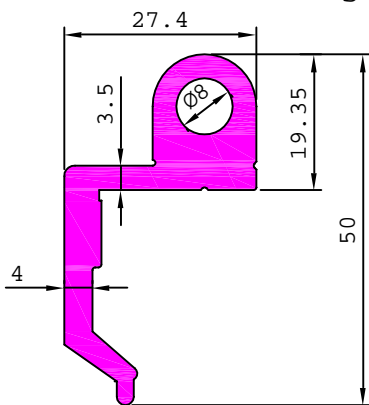

18424 0.896 kg/m

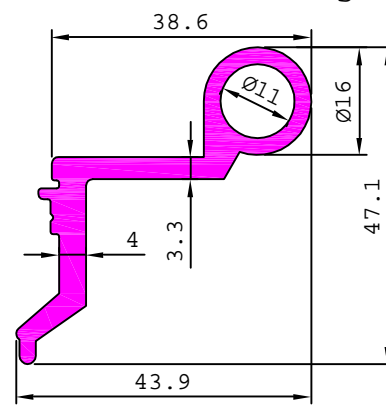

S2017 0.632 kg/m

